



PRODUCT SPECIFICATION

Led Pixel Dot

SH-AD8504





Product Feature

- ◇ Independent intellectual property rights, private model design, dedicated to engineering projects.
- ◇ It adopts special die-cast aluminum material with high mechanical strength and good heat dissipation performance.
- ◇ The high-brightness full-color lamp beads are used, and the illumination angle is large.
- ◇ It is made of PU glue and is not easy to crack, and the product protection level is high.
- ◇ The wire and outer casing are made of cold resistant, UV resistant and flame retardant materials, suitable for long outdoor use.

Size Chart

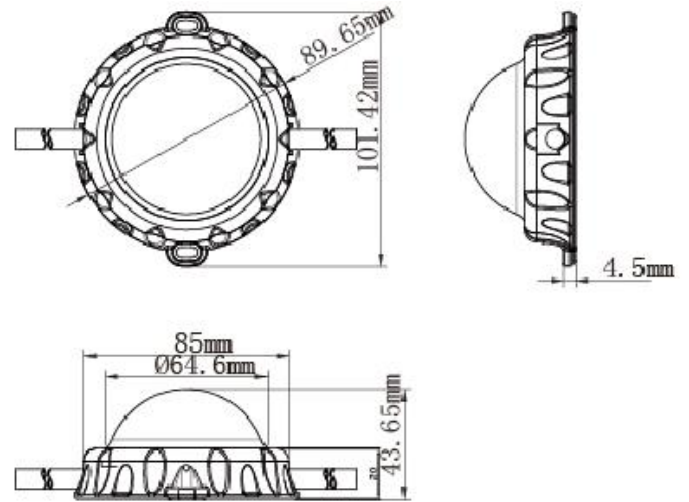

Specification

Model:	AD8504
Voltage:	DC24V
Power:	2.88W
LED Type & Qty:	12pcs SMD 2835W
Chip Type:	UCS512C4
Control mode:	DMX
Shell Material:	Die-cast aluminum / PC
Gray Level:	8 Bit 256 grade
IP Grade:	IP68
Brightness:	≥28800MCD
Color Temp.:	CCT:2000-6500K
Chip Brand:	Osram
Lifespan:	≥30000H
Beam Angle:	≥120°
Work Temp:	-20°C~+60°C
Store Temp:	-40°C~+75°C

Light Distribution Curve

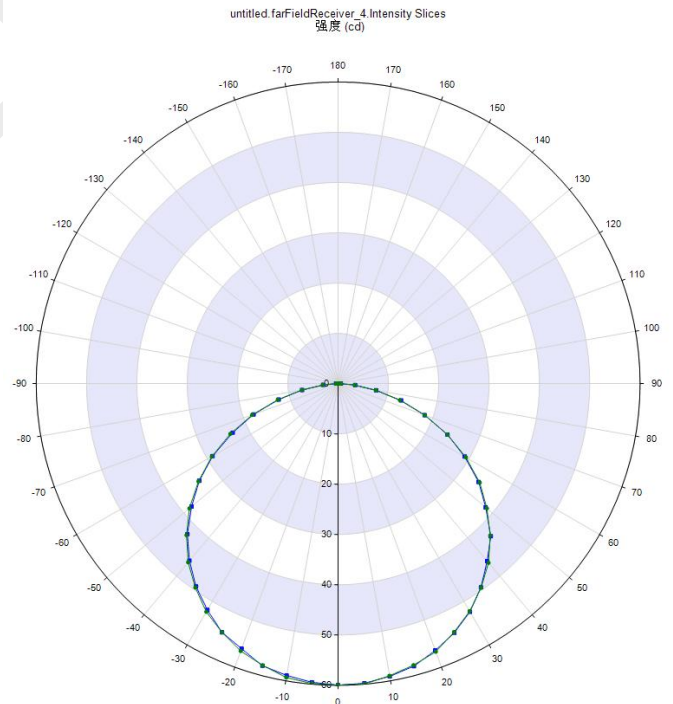



Application

- ◆ Large urban landscape for multi-unit facade media screen linkage
- ◆ Decorative lighting for large buildings such as high-rise buildings and bridges
- ◆ For outdoor lighting, outdoor venues, star hotels, parks, etc.

Reliability Test Item And Conditions

Test Item	Test Conditions	Test Duration	Judgement standard
Power Test	Input Voltage 24V, Ta=25°C±5°C	30min	Wattage 2.88W±10%
Temperature Test	Input Voltage:25V with white color	30min	≤60°C
Drop Test	Free fall at 1.2m height	10 Cycles	No damage to the appearance, normal function
Thermal Shock	-40°C(30min) ~ 100°C (30min)	200 Cycles	No damage to the appearance, normal function
Salt Spray Test	5% NaCl	72H	The material is non-corrosive and functional
Anti-UV Test	UV-A, 350-400nm, 60°C	72H	The material is free from aging and discoloration, functioning normally
Switching Cycle Test	ON 25 second / OFF 5 second, ON/OFF cycle	48H / 5000 cycle	Functioning normally
Voltage Test	DC 500V	Once	Functioning normally
ESD Test	3000V	Once	Functioning normally
High and Low Temperature Test	-30°C~65°C, RH 85%	72H	Functioning normally
Tensile Test	Input/output line, pull force 20KG or more	Once	The wire is not broken and functions normally
Vibration Test	Horizontal and vertical direction	4H	Functioning normally
IP Rating	IP68 0.5m underwater	48H	Functioning normally
Flame Retardant Rating	UL94-V0	10 Cycle	Self-extinguishing from the fire, no burning matter falling



Connection Diagram

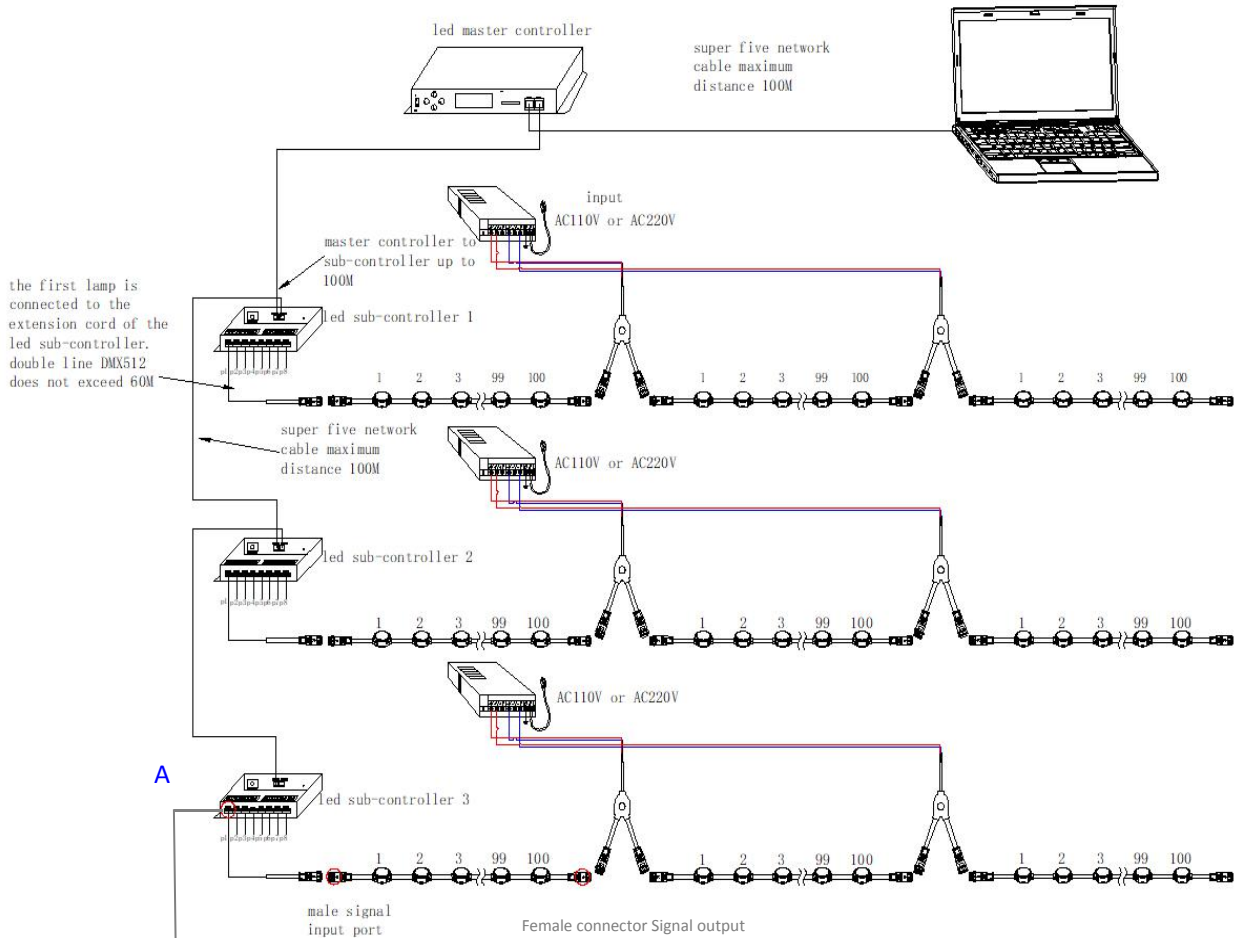

Magnified view A

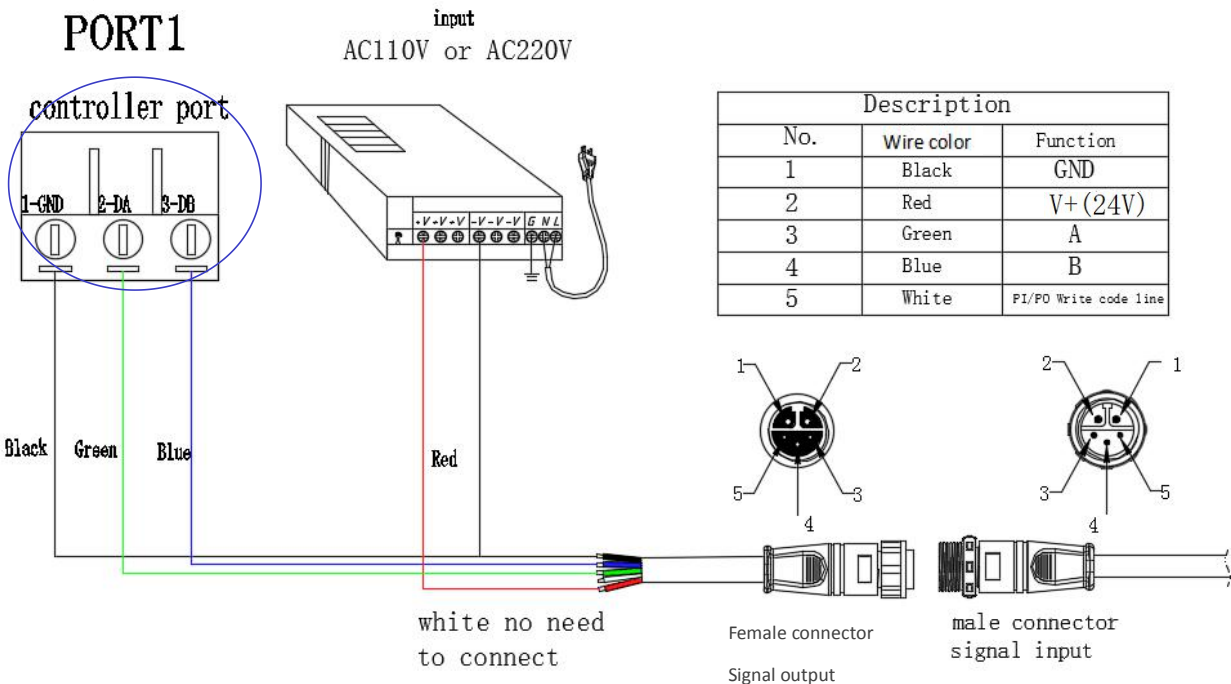

Description		
No.	Wire color	Function
1	Black	GND
2	Red	V+ (24V)
3	Green	A
4	Blue	B
5	White	PI/PO Write code line



Installation Diagram

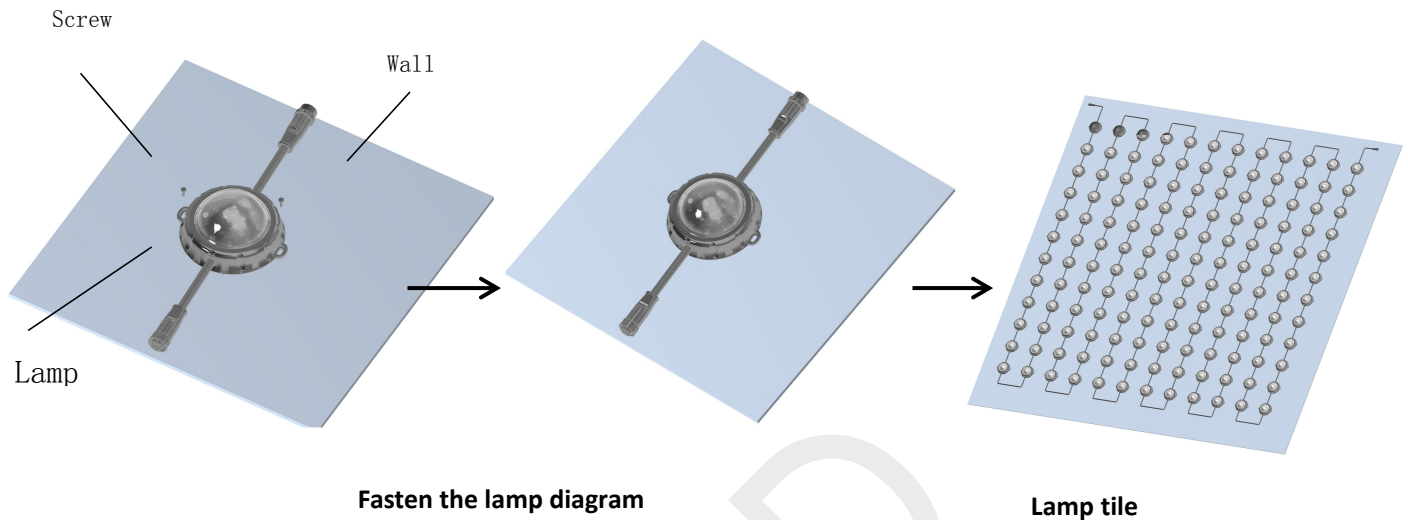

Notes

1. The output voltage of the power supply cannot be higher than the rated voltage, otherwise it will cause damage to the luminaire.
2. Do not carry live work.
3. All power cords and wire connections should be waterproofed after soldering.
4. Non-professionals, please do not replace the controller and power supply at will, avoid wiring errors and cause malfunctions.



Project Case



SH